

RC 枠 アンゲル付

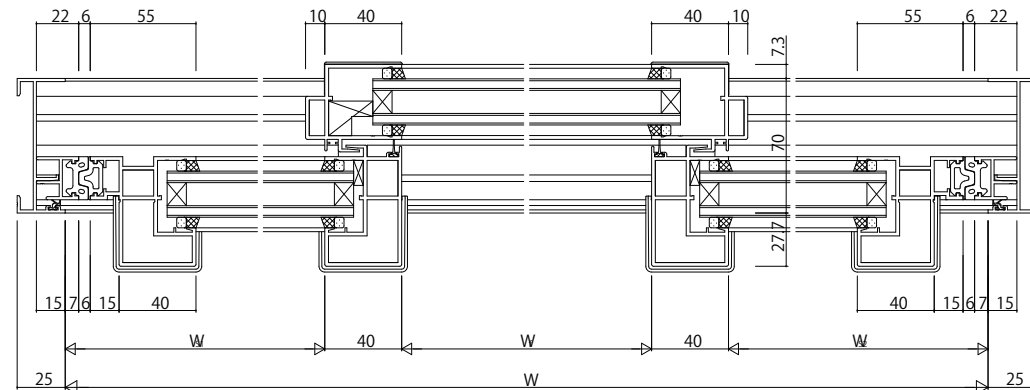
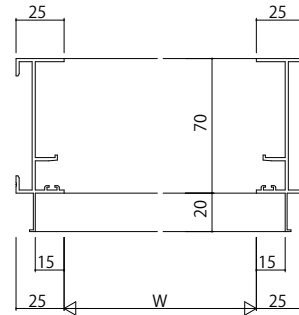
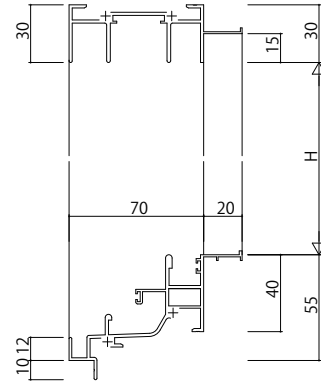

変更記事	

設計監理	
施工	

工事名	RE31S251	工事
図面内容	両袖片引き窓【内動タイプ・緩衝ゴム付仕様】 RC枠 C417 / 35mm溝幅	

照査	担当	作図	尺度	御承認印
			1/1	
				年月日

図番	
通し図番	

