

たて骨部 (突き出し+FIX)

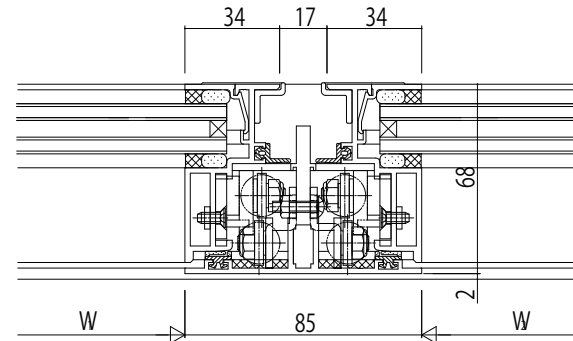

たて骨部 (突き出し+突き出し)

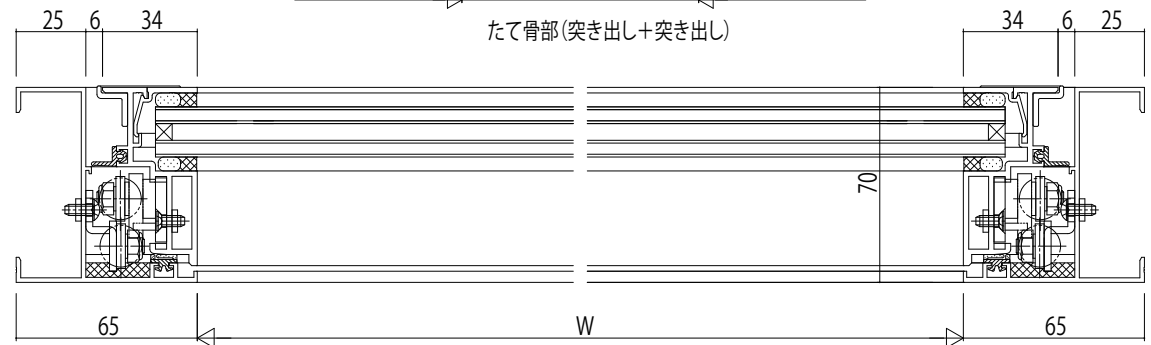

変更記事	設計監理
	施工

工事名	図面内容
SYSTEMA 310 突き出し窓【排煙窓・隠ぺいパネル仕様】	RC枠 28mm溝幅

照査	担当	作図	尺度	御承認印
			1/1	

図番	年月日	通し図番

