

エフルージュ 大型テラス 納まり図

■エフルージュ 独立タイプ

■姿図 (1/25)

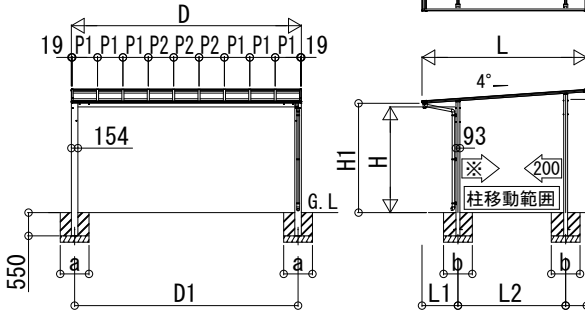

■基礎寸法表

間口呼称	奥行呼称	独立基礎			土間コンクリート考慮基礎		
		地耐力 (kN/m ²)			地耐力 (kN/m ²)		
		30 a・b	50 a・b	100 a・b	30 a・b	50 a・b	100 a・b
48	30	700	600	600	500	500	500
	35	750	650	650			
	39	800	700	700			
51	30	750	600	600			
	35	800	650	650			
	39	850	700	700			
54	30	750	650	650			
	35	850	700	700			
	39	900	750				
60	30	850	750	750			
	35	900					
	39	950					

■柱移動寸法表

奥行呼称	※
30	900
35	600
39	350

■製品寸法表

間口呼称	奥行呼称	高さ呼称	D	D1	L	L1	L2	L3	P1	P2	H	H1	H2	H3					
48	30	25	4838	4683	2997	300	2197	500	600	2500	600	2624	2654	2897					
	35				3497	550	2447					2606	2671	2914					
	39				3897	850	2547					2585	2678	2921					
30	2997		300	2197	2624	2654	2897												
35	3497		550	2447	2606	2671	2914												
39	3897		850	2547	2585	2678	2921												
51	30		5120	4965	2997	300	2197				500	600	2500	494	2624	2654	2897		
35	3497				550	2447	2606								2671	2914			
39	3897				850	2547	2585								2678	2921			
54	30	5438	5283	2997	300	2197	500	600	2500	600				2624	2654	2897			
35	3497			550	2447	2606								2671	2914				
39	3897			850	2547	2585								2678	2921				
60	30	6038	5883	2997	300	2197				500				600	2500	600	2624	2654	2897
35	3497			550	2447	2606											2671	2914	
39	3897			850	2547	2585											2678	2921	

・H=2800の場合、H, H1, H2, H3は300足した寸法にしてください。

■側面図

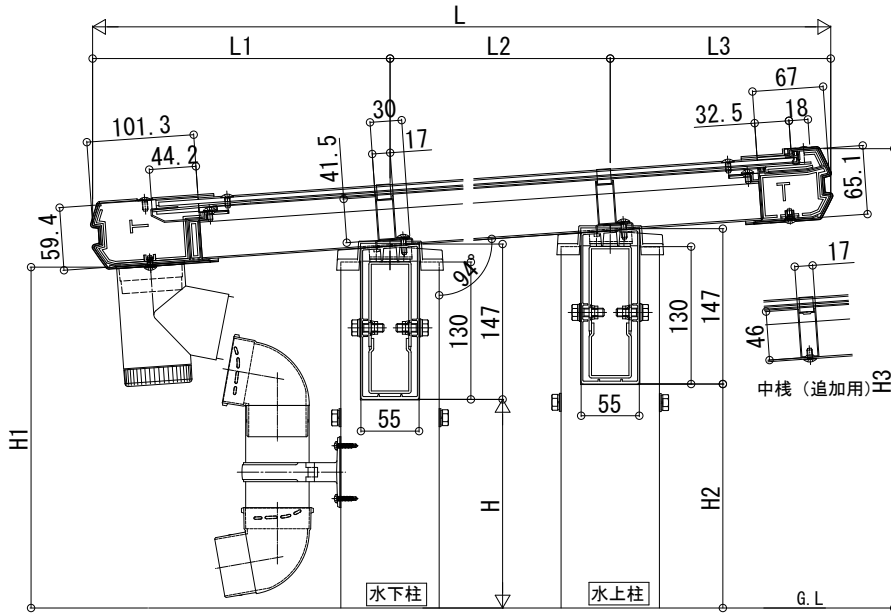

■正面図

